



**January 2017**

# **2017 Official Rules Wakeboard Australia**



## Contents

Rule 1 - GENERAL .....	2
Rule 2 - COMPETITION SITE DURING WAKEBOARD EVENTS .....	3
Rule 3 - SAFETY DURING WAKEBOARD AUSTRALIA SANCTIONED EVENTS .....	3
Rule 4 - CATEGORIES AT THE WAKEBOARD AUSTRALIA STATE AND NATIONAL EVENTS.....	4
Rule 5 - HEAT SYSTEM.....	5
Rule 6 - RIDER PREPAREDNESS .....	5
Rule 7 – DISQUALIFICATION.....	5
Rule 8 – ADVANCEMENT.....	5
Rule 9 - ENTRY REQUIREMENTS FOR WAKEBOARD AUSTRALIA NATIONAL CHAMPIONSHIPS .....	6
RULE 10 - TEAM SCORING.....	7
Rule 11 - BIBS.....	8
Rule 12 – EQUIPMENT .....	9
Rule 13 - RE-RIDES.....	10
Rule 14 - PROTESTS.....	10
Rule 15 - USE OF VIDEO .....	11
Rule 16 - COMPETITION FORMAT.....	12
Rule 17 - WAKEBOARD COURSE.....	13
Rule 18 - DOUBLE-UP .....	13
Rule 19 - OBSTACLES.....	14
Rule 20 - BOAT SPEED & ROPE LENGTH.....	14
RULE 21 - FALLS.....	14
RULE 22 - SCHEDULE CHANGES & CANCELLATION OF EVENTS .....	15
<b>Diagram 1 - OFFICIAL WAKEBOARD COURSE .....</b>	<b>16</b>
<b>Diagram 2 – DOUBLE-UP ILLUSTRATION .....</b>	<b>16</b>
<b>ATTACHMENT A - PROTEST LODGEMENT SHEET .....</b>	<b>17</b>
<b>ANNEXURE 1 - HEAT SYSTEM .....</b>	<b>18</b>



## Rule 1 - GENERAL

- (a) **Applicability of the Rules:** The rules set forth here govern wakeboard competitions sanctioned by Wakeboard Australia (WBA). It is requested that States and divisions establish rules as close to these rules as possible. Whenever the masculine is used, the same shall be construed as meaning the feminine where the context so requires.
- (b) **Exceptions to the Rules:** Where compliance with the rules is not feasible, the Chief Judge shall, with the approval of the majority of the Judges, make the necessary changes. Such changes will be announced at a riders' or team captains' meeting, and by posting. Where the rules are definite and feasible, a vote of the Judges to decide whether to enforce any provision is prohibited.
- (c) **Drug Testing:** All competitors must agree to be subject to doping control. Specific policies and procedures regarding doping control shall be detailed in the Medical Regulations of Water-ski & wakeboard Australian (WAWA).
- (d) **No alcohol is to be consumed by Athletes or officials prior to or during the day's event.** The days event is deemed as starting 1 hour prior to the first rider starting their run and finished when the final scores for have been posted and the official protest time has elapsed. Once an athlete's heat and results are posted it is deemed that the athlete's day is finished. However, if in the opinion of the Chief Judge, Safety Officer or Dock Marshall a rider or official is under the influence of alcohol they will not be allowed to participate in the tournament.
- (e) **Unsportsmanlike Conduct:** Any rider (or his representative) or official whose conduct is deemed unsportsmanlike or whose conduct may cause discredit to Wakeboard Australia, WAWA and sponsors, either on or off the competition site, before during, or after the competition, may be disqualified from all or part of the competition including completed events and/or be subject to a fine to be determined by the WBA Executive Board, by a two-thirds majority vote of the Judges. Any and all infractions can also be punishable by disqualification of the whole team.

Unsportsmanlike conduct includes, but is not limited to: use of vulgar language in public, public tantrums, not riding to fullest potential, failure to attend designated functions or events, consuming alcoholic beverages during or before the competition, use of prohibited substances, competing under false pretences, concealing significant injuries or health problems.

This also includes but is not limited to riders and individuals who choose to vandalise or misrepresent wakeboarding at official hotels venues or functions during the event.

Each rider, prior to participating, will sign a code of conduct as a condition of entry.



## Rule 2 - COMPETITION SITE DURING WAKEBOARD EVENTS

- (a) There will not be any official familiarisation during the National Championships at the event site or behind the official towboat 7 days prior to the event.
- (b) The organizers of the event will hand the site over to the Chief Judge one full day prior to the first day of the event for inspection.
- (c) Use of the site is under the authority of the Chief Judge until the completion of the competition.
- (d) At the discretion of the Event organiser, and only with the approval of the Chief Judge, riders may be selected to ride or partake in a course testing, and/or media, promotional or sponsorship obligations.

## Rule 3 - SAFETY DURING WAKEBOARD AUSTRALIA SANCTIONED EVENTS

- (a) **Safety Director:** At least one month before the Wakeboard Event, the host State shall appoint a Safety Director, who will appoint such assistants as appear necessary and inform the Wakeboard Australia President and Chief Judge. The Safety Director shall be responsible for the safe conditions of all equipment, facilities and operation of the event; but this shall not prevent him from delegating specific responsibilities to his assistants as approved by the Chief Judge. He shall have the authority to take whatever action is necessary, including stopping the event, whenever he observes a condition he believes unsafe. The Chief Judge may overrule any contemplated action or decision of the Safety Director on his own responsibility.
- (b) **Unsafe Rider Disqualification:** No rider shall be allowed to compete or to continue to compete if, in the opinion of the Safety Director and a majority of the Boat Judges, his competing would be a danger to himself or other riders in the competition. During the competition, the Safety Director may, at any time, request the Chief Judge to halt the event for a poll of the Boat Judges in regard to a rider's actions or conditions. Whenever practical, the advice of a doctor should be obtained.
- (c) **Safety Boats:** Two safety boats shall be used during the event. The suggested positioning of the safety boats is operating outside the wakeboard course buoys facing a rider during his pass.
- (d) **Safety Boat Personnel:** Each safety boat will be manned by:
  - i. An experienced driver who is familiar with the conduct of all practice and competitive events.
  - ii. An experienced observer, Wakeboard Australia recommends that where possible he or she will be a swimmer, who is fully trained in First Aid, Emergency Resuscitation and Water Rescue Techniques. The swimmer will wear a life jacket at all times and, in the event of a serious fall, will jump into the water to assist the rider. If the injured rider is unable to climb into the safety boat with little or no assistance, the rider will be floated to shore and lifted from the water on a suitable board or stretcher. Under no circumstances will an injured rider be lifted passively over the side of the safety boat.



- (e) On Site Medical Facilities: The Safety Director will appoint a Competition Medical Officer who will undertake to provide the following services:
- i. A suitably qualified medical officer will be in attendance during throughout the event.
  - ii. A suitably equipped medical station prepared to deal with any sort of medical emergency will be conveniently located at the competition site.
  - iii. Suitable transportation facilities that will allow an injured rider to be moved safely and promptly to the best local medical unit for further care.
  - iv. A working relationship will be established between the local hospital or medical unit and the Competition Medical Officer, such that casualties will get prompt and expert treatment when required.

## Rule 4 - CATEGORIES AT THE WAKEBOARD AUSTRALIA STATE AND NATIONAL EVENTS

- (a) Competition entry at Wakeboard Australia Nationals events will be strictly by age with the exception of the Open/Pro category.
- (b) There will be a minimum of 3 riders required to open a category or that the discretion of the chief judge. The Chief Judge will inform all participating states as soon as feasibly possible if there are insufficient riders within a category. The Chief Judge can reduce the number of competitors required to open a category if it is deemed in the best interest of the sport.
- (c) A rider will only be allowed to enter one category.
- (d) The Chief Judge and/or Chief Calculator will ensure that all riders' birth dates are checked for verification of age.
- (e) The Wakeboard Australia Season will commence on the 1<sup>st</sup> of July and will end on the 30<sup>th</sup> June.
- (f) The riders age at 30th of June at the end of the Wakeboard Australia Season is the division Riders enter at the beginning of the season.
- (g) Wakeboard Australia Age Divisions are as follows.

Age Criteria	Division Name
9 and under	Junior Boys & Junior Girls
10-14	Boys & Girls
15-18	Junior Men & Junior Women
19-29	Men & Women
30-39	Masters Men & Master's Women
40+	Veteran Men & Veteran Women
Any Age	Open Men & Open Women
Any Age	Adaptive



## Rule 5 - HEAT SYSTEM

Wakeboard competitions will use a heat system. The running order for the first round of competition will be randomly selected by either computer or drawn from a ballot in order to compete in individual heats. The number of riders in each is dependent on the total number of riders entered.

No heat shall exceed 6 riders, where possible heats of 4 or 5 are preferred. An equal amount of riders from each heat will then advance to the semi-finals and finals. The LCQ, Semi-finals and Finals will be selected from placement **not** scores.

Advancing riders will be seeded from placement and then heats will be selected using the following method. 2 Heats 2-1-1-2 or for 3 heats 3-2-1-1-2-3 and so forth. This allows for the heats to be mixed throughout the event

The number of riders in each heat is dependent on the total number of riders entered. There will be a maximum of 6 riders in each heat. A percentage of the riders from each heat will then advance to the semi-finals and finals. The running order for the LCQ, Semi Finals and Finals will be selected from placement and NOT scores.

All Finals will comprise of 6 riders, in the event of a withdrawal, injury or disqualification the rider will not be replaced or substituted. The final heat will proceed with fewer riders.

The Last Chance Qualification round may or may not be used within the competition, dependent on time and numbers.

See **Annex 1** for the Official Heat System.

## Rule 6 - RIDER PREPAREDNESS

A rider must be in his bindings, with his life vest and assigned bib on, and with a rope that will not interfere with him being ready to ride when the boat returns to the dock/start area. Any rider who fails to be on immediate hand & in condition to ride when it is his turn in the running order as stated above will be deemed to be wasting time to gain an unfair advantage and **will be disqualified**.

In the case where a rider has been disqualified or has been scratched, a one-minute delay shall be granted to the next rider in the starting order if he was not on the starting dock at the time of disqualification. If more than one rider has been disqualified or has scratched, the time allotted to the next rider shall be one minute for each rider disqualified or scratched.

Riders are expected to be onsite at least 1 hour prior to their scheduled start time.

## Rule 7 – DISQUALIFICATION

Should a rider be disqualified for any reason, he will not be permitted to participate in the remainder of the competition, ie. If he misses his turn in the qualifying rounds, he will not be permitted to compete in the last chance qualifiers.

## Rule 8 – ADVANCEMENT

A rider must score (more than 0) in the qualifying round to advance to the next round of competition.

## Rule 9 - ENTRY REQUIREMENTS FOR WAKEBOARD AUSTRALIA NATIONAL CHAMPIONSHIPS

- (a) Rider Eligibility: Each rider must be a full financial member of the Australian Waterski and Wakeboard Federation (or hold equivalent overseas membership status as recognised by IWSF).
- (b) A rider must compete in a minimum of two state sanctioned event to be eligible for entry to state championships, and then a rider must enter and ride at a state championships to be eligible to enter the National Championships unless an exemption is sought by the State President & ratified by the National President
- (c) Riders must ride in the National championships in the age division in which they competed at their State Championships & compete for the State they registered membership with in that season
- (d) A rider may advance to Open / Pro at national Level if they choose
- (e) Each state may select a team of 8 riders to represent in a state team challenge. **States must nominate their team riders by 8:00 pm on the day before the event, after which all riders will be considered individual entries.** In the event of an injured rider, the Team Captain can replace a rider but only within the same category. Replacements are not permitted once the event begins.
  - i. Individual Entries: Riders who are not part of a team may compete as individuals. An individual rider's entry can be submitted to the Chief calculator no later than 2 weeks prior to the event.
  - ii. Reigning National Champions Riders: Riders may compete in the Wakeboard Australia National Championships as individuals if they are the reigning National Champion in any event from the previously held Wakeboard Australia Championships. The rider must be a full financial member.
  - iii. At the discretion of the President of Wakeboard Australia, elite riders participating in IWSF World Cup events may be invited to participate in the Australian National Championships.
- (f) Late Entries
  - i. Entry Deadline: The cut-off date for submitting entries is two weeks prior to the event commencement, after which penalties will apply.



## RULE 10 - TEAM SCORING

- (a) The best 6 scores will be used to compute an overall team score.
- (b) Each team rider will be awarded the following points depending on his final placement in his respective category:

Placing	Points
1st place	100 points
2nd place	80 points
3rd place	65 points
4th place	55 points
5th place	45 points
6th place	35 points
7th place	30 points
8th place	25 points
9th place	20 points
10th place	17 points
11th place	14 points
12th place	11 points
13th place	8 points
14th place	6 points
15th place	5 points
16th place	4 points
17th place	3 points
18th place	2 points
19th place	1 point
20th place and all subsequent riders receive 1 point each	

With the use of the heat system, there will be instances where riders have finished in a joint position with a rider in a different heat. Relevant placing points will therefore be given to each individual, for example:

SEMI-FINALS – HEAT 1	
	1st place
	2nd place
	3rd place
	4th place
	5th place (equal 9th place) 20 points
	6th place (equal 11th place) 14 points
	7th place (equal 13th place) 8 points
	8th place (equal 15th place) 5 points

FINALS	
	1st place 100 points
	2nd place 80 points
	3rd place 65 points
	4th place 55 points
	5th place 45 points
	6th place 35 points
	7th place 30 points
	8th place 25 points



SEMI-FINALS – HEAT 2	
	1st place
	2nd place
	3rd place
	4th place
	5th place (equal 9th place) 20 points
	6th place (equal 11th place) 14 points
	7th place (equal 13th place) 8 points
	8th place (equal 15th place) 5 points

- (a) In the event of a tie, final team placement will be determined by the 7th team score.
- (b) If a team rider is disqualified no points shall be awarded for this rider. No substitutions allowed.

## Rule 11 - BIBS

Riders are required to wear an official bib during media riding, & actual competition. If a rider is not wearing a bib that is assigned to him while competing, he may be disqualified from the tournament at the Chief Judges discretion. No modifications of bibs or addition or deletion of lettering or logos on bibs are permitted.



## Rule 12 – EQUIPMENT

- (a) General: All personal equipment is subject to the approval of the Chief Judge and Safety Director
- (b) Life Vest: All competitors must wear a life vest. It is the responsibility of each rider to ensure their life vest meets the following specifications:
  - i. It must float the rider.
  - ii. It must be constructed so as to provide adequate protection from impact damage to the ribs and internal organs.
  - iii. The vest must be Australian Standards Approved PFD2 or PFD3.
  - iv. The vest must be in good repair
- (c) Towlines: Riders just provide their own handles and ropes which must be of a non-stretch material.
- (d) Helmets: Riders must wear a suitable helmet if they choose to hit any of the obstacles in the wakeboard course. If a rider hits an obstacle without a helmet, he will be disqualified from the competition. If a rider wishes to hit any obstacles, he must start and complete his routine with a helmet on. This includes double ups. There are currently no ASA helmets, therefore all helmets used should have a break away strap.
- (e) Boats: The total additional weight in the boat will be determined by the Chief Judge and a representative from the Wakeboard Australia's technical committee. If a representative from the technical committee is not present, then the decision will be at the discretion of the Chief Judge.
- (f) Damaged Equipment: A rider is fully responsible for his personal equipment and should have a **spare board, fully assembled with bindings and fins**, at his disposal should any damage occur. In the event that a rider realises his equipment has been damaged, he may throw the handle to indicate that he wishes to repair his equipment. This will, however, constitute one fall if it occurs in the wakeboard course. If a rider falls in the wakeboard course due to his equipment being damaged, it will also constitute one fall. The Chief Judge will have the final say as to whether the equipment has failed. If a rider has damaged his equipment, he will have **four minutes** to repair the equipment. The damaged equipment must be repaired at the starting dock. The time begins when the rider gets onto the starting dock. The rider must have both feet back in his bindings before the four minutes elapses or his routine is over. The boat will then tow the rider from the starting dock to the location of the fall or handle-throw, come to a complete stop and then resume the routine.



## Rule 13 - RE-RIDES

**It is the sole responsibility of a rider to lodge a request for a re-ride.**

When unfair conditions occur, which, in the opinion of a majority of the Judges adversely affects a rider; he shall be granted the option of a re-ride only on the passes affected. Re-rides will not be granted if a rider's personal equipment fails. Re-rides must be taken immediately. If a rider is given a second re-ride, he may elect to take a five-minute rest, during which the next rider in order will perform his routine.

The re-ride shall be taken at the conclusion of the rider's routine during which the five-minute rest period expires.

Requests for re-rides may be initiated by a Boat Judge for the event before the next rider starts or may be initiated, as soon as possible, by the rider or his team representative and shall be decided as soon as practicable thereafter. If, in the opinion of the Boat Judges for the event, the request was not initiated as soon as possible after the rider has ridden, the request shall be denied.

Re-ride requests will not be permitted if they are based on variations in weather or water conditions.

## Rule 14 - PROTESTS

Protests shall be made by a rider to the Chief Judge only. Protests must be made in writing, must state the reason(s) for the protest, and must be filed as soon as possible, but no later than 20 minutes after the occurrence or after the results of the event are announced. A protest can only be made by the athlete involved or his/her guardian.

**(Protest Lodgement Sheet: see attachment A).**

If a rider decides to file a protest, he/she must fill out a rider run sheet including the tricks he/she performed. The rider must then indicate what category of their run and results they are questioning.

Protests must be accompanied by a \$100 lodgement fee - This amount will be refunded if the protest is upheld by the Judges.

If aged under 18 the rider may be assisted by their parent and/or guardian during this process. Other riders may choose to have a suitable advocate work with them in lodging their protest, for example their state president may be called on to assist. The conduct of any assisting any advocate will be subject to the same conduct rules as a rider, parent or guardian.

The Chief Judge will then review the rider run sheet and score sheets to ensure the judges have the tricks written down correctly. If the tricks are correct, the Chief Judge may dismiss the protest. If the Chief Judge finds a discrepancy on any of the judges score sheet he will meet with the judge immediately. The judge will make sure that the discrepancy is addressed on his sheet and he will re-evaluate his scores to make sure his placements are correct. If the judge makes a change the chief judge will have the score keeper record the change and post new results. There may or may not be a change in placements after a judge changes his score.

If the chief judge evaluates the judge's sheets and is unsure on the decision of the judge in question he will meet with the judges immediately and ask them to double check their decision. If they are certain on their decision the issue is over.



The results are final. If the judge makes a change the chief judge will have the chief calculator record the change and post new results. There may or may not be a change in placements after a judge changes his/her score. If needed, and at the discretion of the Chief judge only, all judges may meet with the rider to discuss the protest.

The Chief Judge will make his best efforts to communicate the results of the protest to the rider within 20 minutes of the protest being presented. The Chief Judge has the final say in the protest.

Any rider, parent, guardian or advocate who raises their voice, harasses the Chief Judge or uses profanity during the protest will be subject to the code of conduct and any applicable disciplinary action. The Chief Judge may also, at their discretion, call the protest closed at that point, and there will be no requirement to continue hearing details of the protest.

No rider, parent, guardian or advocate is allowed to approach the individual judges on protest issues. Any rider or guardian found harassing judges or using profanity during the protest will be subject to the code of conduct and any applicable disciplinary action. The protest will also be deemed to be over at that point.

If a rider and/or their guardian would like to look over their sheets to educate themselves for the future they may do so after the protest period is over. They may also speak with the judges individually when the judges have free time. Any rider, parent, guardian or advocate found harassing judges or using profanity when attempting to discuss details of their individual ride and associated results will be subject to the code of conduct and any applicable disciplinary action.

If a rider wishes to make a protest while on the water, the protest needs to come by radio to Chief Judge's station. The Chief Judge will be on hand to hear the protest. The Chief Judge will record the protest on the Official Protest form until the rider is able to sign and complete the form. The Chief Judge will then take the proper steps to resolve the protest.

All judges must be at the Chief Judge's station immediately following the last event each day and will remain 20 minutes after the release of the official results to answer questions.

Protests will be handled by the Chief Judge and the 3 judges involved in the respective event. In the case of other protests, ie. heat protests, timing, etc, such protests shall be handled by the majority of judges.

Due to its subjective scoring nature and in the spirit of wakeboarding protests shall be allowed only for failure of the judges and calculators to comply with these rules and only if the non-compliance with rules has an adverse effect on a rider. No protest shall be permitted on a judgement or decision by the Boat Judges.

A correction of an error in the computation of scores shall not be considered a protest and the correction shall be made on the approval of the Chief Judge and Calculator within 20 minutes after the results are announced, and Boat Judges' scoring sheets have been made available for inspection. The inspection of scoring sheets will be done only in the presence of the Judges scoring that particular event.

## Rule 15 - USE OF VIDEO

Due to the subjective scoring nature & spirit of wakeboarding, video footage of any kind will not be used by Judges, riders or team representatives to resolve any disputes. Judges will not view or comment on any video footage during the event.



## Rule 16 - COMPETITION FORMAT

- (a) General: Each rider shall be allowed two passes through the wakeboard course during which time he may perform any routine he chooses. He will be judged on subjective tyle categories, to arrive at a single combined score.

Judging of the routine begins when the rider enters the wakeboard course and ends when the rider exits the wakeboard course, falls for a second time, or completes his double-up (finals only).

Riders are encouraged to perform a smooth flowing routine with a wide variety of tricks. Each manoeuvre should be different and executed as cleanly as possible and taken to its limit.

Boat (Scoring) Judges: The Chief Judge will designate three Boat Judges, to be seated in the tow boat, to score each rider's routine.

- (b) Scoring: Judges will award a maximum of 100 points to each rider based on their overall impressions of the routine performed. Each individual heat per division will be judged independently from the other heats on the day. The judges will score the first rider of the heat subjectively and each subsequent riders performance after that rider is judged higher or lower dependant upon their ride. Judges are required to both score and placement a rider in within each heat.

The judges will score each rider in each of the following categories:

Type	Points	Description
Execution	33.3 Points	This reflects the level of perfection to which each manoeuvre was performed, as well as the successful completion of the routine with a minimum number of falls.
Intensity	33.4 Points	This reflects how big the moves were performed, as well as the technical difficulty of the tricks executed.
Composition	33.3 Points	This reflects the overall composition of the routine in terms of the rider's ability to perform a variety of manoeuvres in a flowing, creative sequence

- (c) Calculation of Scores: The Average method of calculating will be used. Scores from all categories of a rider's routine are added together to produce a judge's total score. All three judges' total scores are then averaged to produce a final score for a rider.
- (d) Calculation scores will be cross referenced to the judge's placement of the rider. A judge's placement will override the judge's score.
- (e) In addition to the chief calculator and chief judge signing off on results sheets, the three boat judges must also sign off on the results sheets.



## Rule 17 - WAKEBOARD COURSE

- (a) Course Buoys: Buoys to be used for the wakeboard course must be of the following specifications:
- i. Only inflatable buoys may be used, and they should be made of a lightweight, pliable material with smooth exposed surface.
  - ii. Colour of buoys shall be selected for maximum visibility. A fluorescent orange paint must be used for the start buoy and fluorescent green paint is recommended for the cut-off buoy
  - iii. Start buoys shall not stand be more than 1 metre high above the waterline.
  - iv. Each buoy shall have a strong loop for attaching anchor lines. The buoys must be attached to the anchor line by the use of a system that will tighten the buoy in such a way as to ensure that it does not move around from its position.
- (b) Course Dimensions: A start buoy shall establish the approximate area of the beginning of the wakeboard course from each direction. The end of the pass shall be signified by an end buoy. The distance from the start and end buoys will be a minimum of 370 metres. These course dimensions will be used where practical. Bright orange buoys are recommended for the start and end buoys
- (c) Cut-Off buoy: A cut off buoy will indicate the point after which the tow boat will not be able to get up to speed for a rider to continue his run in the second pass. Bright green buoys will be used for the cut-off buoy. The position of the cut off buoy will be determined by the Chief Judge and Chief Boat Driver. The cut-off buoy will not be used in finals where there is a double-up.
- (d) Proceeding through the two wakeboard passes: The boat shall follow as closely as possible the path specified by the Chief Judge for the event, such path to include the preparation time before each pass. The second pass shall be in the opposite direction from the first pass.
- (e) A rider's routine will begin when he performs his first trick at, or after the start buoy.
- (f) A riders routine will end: when he falls for a second time or when he passes the end buoy. A rider's last trick will be scored if he leaves the crest of the wake before passing the end buoy.
- (g) Any rider who swims down the course to gain advantage over a fellow competitor will be towed back to the point where they started swimming. This will be at the Chief Boat Judges discretion.

## Rule 18 - DOUBLE-UP

Each rider who qualifies for the finals will be given a double-up. It is the sole responsibility of each competitor to communicate to the driver before leaving the dock whether he would like a left or right double-up (**see Diagram 2**), and where the double-up will occur in the course. Re-rides will not be granted due to any miscommunication between the rider and driver.

In the event that the boat provides a double-up in an incorrect direction, the rider must wave off the double-up and not attempt any manoeuvre. If any manoeuvre is attempted, which includes cutting at the wake, the rider will be deemed to have accepted his double-up.

If a rider waves off the double-up, the boat will then turn around, and proceed with a double-up in the correct direction. Re-rides will not be granted for turbulent water in this instance. If a rider's first fall occurs beyond the cut-off buoy, the boat will then immediately proceed with a double-up for the rider.

## Rule 19 - OBSTACLES

Organisers are encouraged to use obstacles where practical and possible, subject to site conditions and logistics.

The obstacles may comprise of the following:

Slider	Kicker
<p>Obstacles must be manufactured with the following prerequisites: -</p> <ul style="list-style-type: none"> <li>• structural integrity</li> <li>• safety</li> <li>• adequate floatation and stability</li> </ul>	

The apparatus must not be gap or Ollie on style obstacles. There must be no hazardous gaps or protruding screws/ fittings on the obstacle. A safety check must be carried out prior to the event.

The Chief Judge will make a final decision on whether the obstacles meet the above criteria.

The Chief Judge will make the decision where to place these obstacles in the wakeboard course. Riders are encouraged to hit these obstacles to add variation to their routines. Riders in all divisions other than Under 9's, Novice and Day Members are permitted to hit the obstacles.

The obstacles may also signify the beginning of each routine depending on where they are placed.

## Rule 20 - BOAT SPEED & ROPE LENGTH

Each rider shall receive his choice of a constant speed through the course for each pass, and preferred rope length. The boat speed, assuming it is held constant before entering the course, is the rider's responsibility.

## RULE 21 - FALLS

- (a) Out-Of-Course Falls: A rider may have one out-of-course fall only before the start of his first pass.
- (b) Handle-Throw: The rider may also have one handle-throw before the start of his first pass which will also count as one out-of-course fall.
 

If a rider throws the handle prior to the start of his first pass to indicate that his rope was incorrectly put on the wrong loop by the officials or Judges in the boat, it will not count as an out-of-course fall.
- (c) An out-of-course fall or handle throw before the start of the second pass will count as one in-course fall.
- (d) Two Falls: A rider may have a maximum of two falls during a routine. Should a fall occur, the boat will pick up the rider to proceed with the routine. The rider will not be picked up after a second fall, or after a fall that occurs beyond the cut-off buoy in the second pass.
- (e) Obstacles: When obstacles are used, each rider will receive one obstacle and one wake/water fall only.



- Example one: A rider falls on the slider, and then falls on his first manoeuvre off the wake, the rider will be picked up. But his pass will end if he falls on either an obstacle or water trick.
  - Example two: A rider falls off the rainbow slider, and then falls off the kicker but has no previous wake/water falls. His pass ends
- (f) The rider must be ready to ride immediately upon the boat's return after the first fall, an out-of-course fall, or handle-throw.

## RULE 22 - SCHEDULE CHANGES & CANCELLATION OF EVENTS

Changes in the schedule during the competition shall be made only for weather, water conditions, safety, or a similar reason. Such changes will be announced at a riders' or team captains' meeting, and by posting.

The finals of each category must be completed to determine a winner, even if the Judges are obliged to continue it at a different site. If a final cannot be completed, all riders from the event will compete again where and when possible, until a winner is determined.





## Diagram 1 - OFFICIAL WAKEBOARD COURSE



**Cut Off BUOY** – To be placed at the point where boat can reach rider speed from end buoy of second pass

## Diagram 2 – DOUBLE-UP ILLUSTRATION

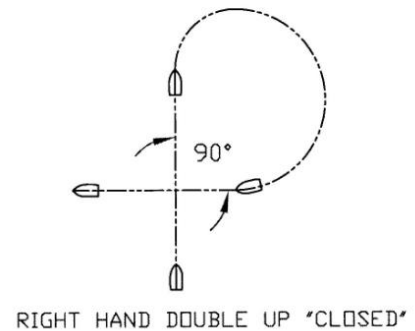
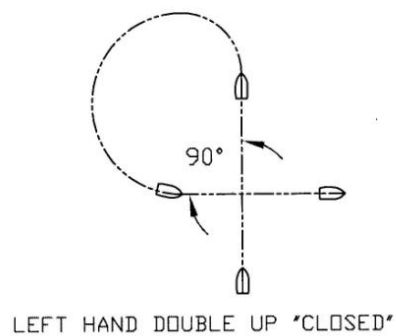
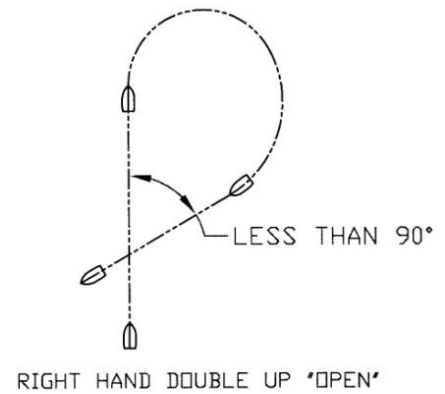
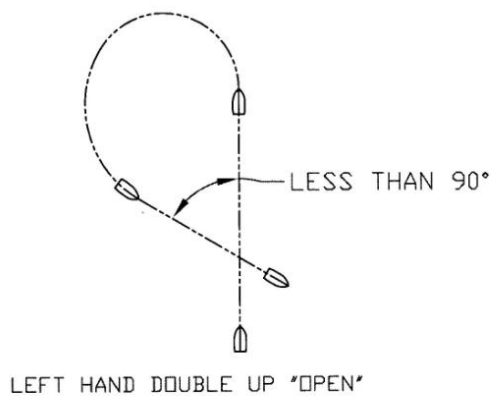



## ATTACHMENT A - PROTEST LODGEMENT SHEET

<b>Name:</b>	
<b>Division:</b>	
<b>Competition Date:</b>	

I have read, understand and agree to the terms laid out in Rule 14 of the Wakeboard Australia Official Rules regarding protests. I agree that I will abide by the Chief Judges decision and will abide by the conduct rules set out in Rule 14. To assist the judges in their review I have provided details below of my protest, including details on the tricks I believe were undertaken in my run.

<b>Signature:</b> (must be signed by parent or Guardian if u18)	
<b>Name of Guardian/parent</b> (if under 18)	
<b>Lodgement fee paid:</b> Yes/No	
<b>Collected by:</b>	
<b>Refunded:</b> Yes/No	
<b>Date:</b>	
<b>Details of protest:</b>	
<b>Run details:</b>	Pass 1
	Pass 2

## ANNEXURE 1 - HEAT SYSTEM

No:	Qualifying	1/4 Final	LCQ	Semi FINAL	FINAL
6 riders				1 Heat	1 Heat 6
7 riders		1 Heat of 3 1 Heat of 4 (Top 2 to Final)	1 Heat of 3  LCQ Top 2 to Final		1 Heat 6
8 Riders		1 Heat of 4 1 Heat of 4 (Top 2 to Final)	1 Heat of 4  LCQ Top 2 to Final		1 Heat 6
9 riders		1 Heat of 4 1 Heat of 5 (Top 2 to Final)	1 Heat of 5  LCQ Top 2 to Final		1 Heat 6
10 Riders		1 Heat of 5 1 Heat of 5 (Top 2 to Final)	1 Heat of 6  LCQ Top 2 to Final		1 Heat 6
11 Riders		1 Heat of 5 1 Heat of 6 (Top 3 to Semi)	1 Heat of 5  LCQ Top 2 to Semi	1 Heat 4 1 Heat 4 Top 3 to Final	1 Heat of 6
12 Riders		1 Heat of 6 1 Heat of 6 (Top 3 to Semi)	1 Heat of 6  LCQ Top 2 to Semi	1 Heat 4 1 Heat 4 Top 3 to Final	1 Heat of 6
13 Riders		1 Heat of 4 1 Heat of 4 1 Heat of 5 (Top 2 to Semi)	1 Heat of 3 1 Heat of 4  LCQ Winner to Semi	1 Heat 4 1 Heat 4 Top 3 to Final	1 Heat of 6
14 Riders		1 Heat of 4 1 Heat of 5 1 Heat of 5 ( To 2 to Semi)	1 Heat of 4 1 Heat of 4  LCQ Winner to Semi	1 Heat 4 1 Heat 4 Top 3 to Final	1 Heat of 6
15 Riders		1 Heat of 5 1 Heat of 5 1 Heat of 5 ( To 2 to Semi)	1 Heat of 5 1 Heat of 4  LCQ Winner to Semi	1 Heat 4 1 Heat 4 Top 3 to Final	1 Heat of 6
16 Riders		1 Heat of 4 1 Heat of 4 1 Heat of 4	1 Heat of 4 1 Heat of 4	1 Heat of 5 1 Heat of 5	1 Heat of 6



	1 Heat of 4 (Top 2 to Semi)	LCQ Winner to Semi	Top 3 to Final	
17 Riders	1 Heat of 4 1 Heat of 4 1 Heat of 4 1 Heat of 5 (Top 2 to Semi)	1 Heat of 4 1 Heat of 5 LCQ Winner to Semi	1 Heat of 5 1 Heat of 5 Top 3 to Final	1 Heat of 6
18 Riders	1 Heat of 4 1 Heat of 4 1 Heat of 5 1 Heat of 5 (Top 2 to Semi)	1 Heat of 5 1 Heat of 5 LCQ Winner to Semi	1 Heat of 5 1 Heat of 5 Top 3 to Final	1 Heat of 6
19 Riders	1 Heat of 4 1 Heat of 5 1 Heat of 5 1 Heat of 5 (Top 2 to Semi)	1 Heat of 5 1 Heat of 6 LCQ Winner to Semi	1 Heat of 5 1 Heat of 5 Top 3 to Final	1 Heat of 6
20 Riders	1 Heat of 5 1 Heat of 5 1 Heat of 5 1 Heat of 5 (Top 2 to Semi)	1 Heat of 6 1 Heat of 6 LCQ Winner to Semi	1 Heat of 5 1 Heat of 5 Top 3 to Final	1 Heat of 6
21 Riders	1 Heat of 4 1 Heat of 4 1 Heat of 4 1 Heat of 4 1 Heat of 5 (Top 2 to Semi)	1 Heat of 5 1 Heat of 6 LCQ Winner to Semi	1 Heat of 4 1 Heat of 4 1 Heat of 4 Top 2 to Final	1 Heat of 6
22 Riders	1 Heat of 4 1 Heat of 4 1 Heat of 4 1 Heat of 5 1 Heat of 5 (Top 2 to Semi)	1 Heat of 6 1 Heat of 6 LCQ Winner to Semi	1 Heat of 4 1 Heat of 4 1 Heat of 4 Top 2 to Final	1 Heat of 6
	Qualifying	LCQ	1/4 Final	Semi FINAL
				FINAL

23 Riders	1 Heat of 4	1 Heat of 4	1 Heat of 4	1 Heat of 4	1 Heat of 6
	1 Heat of 4	1 Heat of 4	1 Heat of 4	1 Heat of 4	
	1 Heat of 5	1 Heat of 5	1 Heat of 4		
	1 Heat of 5		1 Heat of 4		
	1 Heat of 5				
	(Top 2 to 1/4 Final)	LCQ Top 2 to 1/4 Final	Top 2 to Semi Final	Top 3 to Final	

24 Riders	1 Heat of 4	1 Heat of 4	1 Heat of 4	1 Heat of 4	1 Heat of 6
	1 Heat of 5	1 Heat of 5	1 Heat of 4	1 Heat of 4	
	1 Heat of 5	1 Heat of 5	1 Heat of 4		
	1 Heat of 5		1 Heat of 4		
	1 Heat of 5				
	(Top 2 to 1/4 Final)	LCQ Top 2 to 1/4 Final	Top 2 to Semi Final	Top 3 to Final	

25 Riders	1 Heat of 5	1 Heat of 5	1 Heat of 4	1 Heat of 4	1 Heat of 6
	1 Heat of 5	1 Heat of 5	1 Heat of 4	1 Heat of 4	
	1 Heat of 5	1 Heat of 5	1 Heat of 4		
	1 Heat of 5		1 Heat of 4		
	1 Heat of 5				
	Top 2 to 1/4 Final	Top 2 to 1/4 Final	Top 2 to Semi Final	Top 3 to Final	

26 Riders	1 Heat of 6	1 Heat of 5	1 Heat of 4	1 Heat of 4	1 Heat of 6
	1 Heat of 5	1 heat of 5	1 Heat of 4	1 Heat of 4	
	1 Heat of 5	1 Heat of 6	1 Heat of 4		
	1 Heat of 5		1 Heat of 4		
	1 Heat of 5				
	(Top 2 to 1/4 Final)	(Top 2 to 1/4 Final)	Top 2 to Semi Final	Top 3 to Final	

27 Riders	1 Heat of 6	1 Heat of 5	1 Heat of 4	1 Heat of 4	1 Heat of 6
	1 Heat of 6	1 heat of 6	1 Heat of 4	1 Heat of 4	
	1 Heat of 5	1 Heat of 6	1 Heat of 4		
	1 Heat of 5		1 Heat of 4		
	1 Heat of 5				
	(Top 2 to 1/4 Final)	(Top 2 to 1/4 Final)	Top 2 to Semi Final	Top 3 to Final	

28 Riders	1 Heat of 6	1 Heat of 6	1 Heat of 4	1 Heat of 4	1 Heat of 6
	1 Heat of 6	1 heat of 6	1 Heat of 4	1 Heat of 4	
	1 Heat of 6	1 Heat of 6	1 Heat of 4		
	1 Heat of 5		1 Heat of 4		
	1 Heat of 5				
	(Top 2 to 1/4 Final)	(Top 2 to 1/4 Final)	Top 2 to Semi Final	Top 3 to Final	

29 Riders	1 Heat of 5	1 Heat of 4	1 Heat of 4	1 Heat of 4	1 Heat of 6
-----------	-------------	-------------	-------------	-------------	-------------



	1 Heat of 5	1 Heat of 4	1 Heat of 4	1 Heat of 4	
	1 Heat of 5	1 Heat of 4	1 Heat of 4		
	1 Heat of 5	1 Heat of 5	1 Heat of 4		
	1 Heat of 5				
	1 Heat of 4				
	Top 2 to 1/4 Final	Winner to 1/4 final	Top 2 to Semi Final	Top 3 to Final	
30 Riders	1 Heat of 5	1 Heat of 5	1 Heat of 4	1 Heat of 4	1 Heat of 6
	1 Heat of 5	1 Heat of 5	1 Heat of 4	1 Heat of 4	
	1 Heat of 5	1 Heat of 4	1 Heat of 4		
	1 Heat of 5	1 Heat of 4	1 Heat of 4		
	1 Heat of 5				
	1 Heat of 5				
	Top 2 to 1/4 Final	Winner to 1/4 final	Top 2 to Semi Final	Top 3 to Final	
31 Riders	1 Heat of 5	1 Heat of 5	1 Heat of 4	1 Heat of 4	1 Heat of 6
	1 Heat of 5	1 Heat of 5	1 Heat of 4	1 Heat of 4	
	1 Heat of 5	1 Heat of 5	1 Heat of 4		
	1 Heat of 5	1 Heat of 4	1 Heat of 4		
	1 Heat of 5				
	1 Heat of 6				
	Top 2 to 1/4 Final	Winner to 1/4 final	Top 2 to Semi Final	Top 3 to Final	
32 Riders	1 Heat of 5	1 Heat of 5	1 Heat of 4	1 Heat of 4	1 Heat of 6
	1 Heat of 5	1 Heat of 5	1 Heat of 4	1 Heat of 4	
	1 Heat of 5	1 Heat of 5	1 Heat of 4		
	1 Heat of 5	1 Heat of 5	1 Heat of 4		
	1 Heat of 6				
	1 Heat of 6				
	Top 2 to 1/4 Final	Winner to 1/4 final	Top 2 to Semi Final	Top 3 to Final	
33 Riders	1 Heat of 5	1 Heat of 5	1 Heat of 4	1 Heat of 4	1 Heat of 6
	1 Heat of 5	1 Heat of 5	1 Heat of 4	1 Heat of 4	
	1 Heat of 5	1 Heat of 5	1 Heat of 4		
	1 Heat of 6	1 Heat of 6	1 Heat of 4		
	1 Heat of 6				
	1 Heat of 6				
	Top 2 to 1/4 Final	Winner to 1/4 final	Top 2 to Semi Final	Top 3 to Final	
34 Riders	1 Heat of 5	1 Heat of 5	1 Heat of 4	1 Heat of 4	1 Heat of 6

1 Heat of 5	1 Heat of 5	1 Heat of 4	1 Heat of 4
1 Heat of 6	1 Heat of 6	1 Heat of 4	
1 Heat of 6	1 Heat of 6	1 Heat of 4	
1 Heat of 6			
1 Heat of 6			

Top 2 to 1/4 Final	Winner to 1/4 final	Top 2 to Semi Final	Top 3 to Final
--------------------	---------------------	---------------------	----------------

35 Riders	1 Heat of 5	1 Heat of 5	1 Heat of 4	1 Heat of 4	1 Heat of 6
	1 Heat of 6	1 Heat of 6	1 Heat of 4	1 Heat of 4	
	1 Heat of 6	1 Heat of 6	1 Heat of 4		
	1 Heat of 6	1 Heat of 6	1 Heat of 4		
	1 Heat of 6				
	1 Heat of 6				
	Top 2 to 1/4 Final	Winner to 1/4 final	Top 2 to Semi Final	Top 3 to Final	

36 Riders	1 Heat of 6	1 Heat of 6	1 Heat of 4	1 Heat of 4	1 Heat of 6
	1 Heat of 6	1 Heat of 6	1 Heat of 4	1 Heat of 4	
	1 Heat of 6	1 Heat of 6	1 Heat of 4		
	1 Heat of 6	1 Heat of 6	1 Heat of 4		
	1 Heat of 6				
	1 Heat of 6				
	Top 2 to 1/4 Final	Winner to 1/4 final	Top 2 to Semi Final	Top 3 to Final	

37 Riders	1 Heat of 5	1 Heat of 5	1 Heat of 5	1 Heat of 4	1 Heat of 6
	1 Heat of 5	1 Heat of 5	1 Heat of 5	1 Heat of 4	
	1 Heat of 5	1 Heat of 5	1 Heat of 5		
	1 Heat of 5	1 Heat of 6	1 Heat of 5		
	1 Heat of 5				
	1 Heat of 4				
	1 Heat of 4				
	1 Heat of 4				
	Top 2 to 1/4 Final	Winner to 1/4 final	Top 2 to Semi Final	Top 3 to Final	

--	--	--	--	--	--

	<b>Qualifying</b>	<b>1/4 Final</b>	<b>LCQ</b>	<b>Semi FINAL</b>	<b>FINAL</b>
--	-------------------	------------------	------------	-------------------	--------------

38 Riders	1 Heat of 5	1 Heat of 5	1 Heat of 5	1 Heat of 4	1 Heat of 6
	1 Heat of 5	1 Heat of 5	1 Heat of 5	1 Heat of 4	
	1 Heat of 5	1 Heat of 6	1 Heat of 5		



1 Heat of 5                      1 Heat of 6                      1 Heat of 5

1 Heat of 5

1 Heat of 5

1 Heat of 4

1 Heat of 4

Top 2 to 1/4 Final                      Winner to 1/4 final                      Top 2 to Semi Final                      Top 3 to Final

39 Riders	1 Heat of 5	1 Heat of 5	1 Heat of 5	1 Heat of 4	1 Heat of 6
	1 Heat of 5	1 Heat of 6	1 Heat of 5	1 Heat of 4	
	1 Heat of 5	1 Heat of 6	1 Heat of 5		
	1 Heat of 5	1 Heat of 6	1 Heat of 5		
	1 Heat of 5				
	1 Heat of 5				
	1 Heat of 5				
	1 Heat of 4				
	Top 2 to 1/4 Final	Winner to 1/4 final	Top 2 to Semi Final	Top 3 to Final	

40 Riders	1 Heat of 5	1 Heat of 6	1 Heat of 5	1 Heat of 4	1 Heat of 6
	1 Heat of 5	1 Heat of 6	1 Heat of 5	1 Heat of 4	
	1 Heat of 5	1 Heat of 6	1 Heat of 5		
	1 Heat of 5	1 Heat of 6	1 Heat of 5		
	1 Heat of 5				
	1 Heat of 5				
	1 Heat of 5				
	1 Heat of 5				

Top 2 to 1/4 Final                      Winner to 1/4 final                      Top 2 to Semi Final                      Top 3 to Final

**Qualifying                      LCQ                      1/4 Final                      Semi FINAL                      FINAL**

41 Riders	1 Heat of 4	1 Heat of 5	1 Heat of 6	1 Heat of 4	1 Heat of 6
	1 Heat of 4	1 Heat of 5	1 Heat of 6	1 Heat of 4	
	1 Heat of 4	1 Heat of 5	1 Heat of 6		
	1 Heat of 4	1 Heat of 6	1 Heat of 6		
	1 Heat of 4				
	1 Heat of 4				
	1 Heat of 4				
	1 Heat of 4				
	1 Heat of 4				
	1 Heat of 5				



	Top 2 to 1/4 Final	Winner to 1/4 Final	Top 2 to Semi Final	Top 3 to Final	
42 Riders	1 Heat of 4	1 Heat of 5	1 Heat of 6	1 Heat of 4	1 Heat of 6
	1 Heat of 4	1 Heat of 5	1 Heat of 6	1 Heat of 4	
	1 Heat of 4	1 Heat of 6	1 Heat of 6		
	1 Heat of 4	1 heat of 6	1 Heat of 6		
	1 Heat of 4				
	1 Heat of 4				
	1 Heat of 4				
	1 Heat of 5				
	1 Heat of 5				
	Top 2 to 1/4 Final	Winner to 1/4 Final	Top 2 to Semi Final	Top 3 to Final	
43 Riders	1 Heat of 4	1 Heat of 5	1 Heat of 6	1 Heat of 4	1 Heat of 6
	1 Heat of 4	1 Heat of 6	1 Heat of 6	1 Heat of 4	
	1 Heat of 4	1 Heat of 6	1 Heat of 6		
	1 Heat of 4	1 Heat of 6	1 Heat of 6		
	1 Heat of 4				
	1 Heat of 4				
	1 Heat of 4				
	1 Heat of 5				
	1 Heat of 5				
	1 Heat of 5				
	Top 2 to 1/4 Final	Winner to 1/4 Final	Top 2 to Semi Final	Top 3 to Final	
	<b>Qualifying</b>	<b>1/4 Final</b>	<b>LCQ</b>	<b>Semi FINAL</b>	<b>FINAL</b>
44 Riders	1 Heat of 4	1 heat of 6	1 Heat of 6	1 Heat of 4	1 Heat of 6
	1 Heat of 4	1 heat of 6	1 Heat of 6	1 Heat of 4	
	1 Heat of 4	1 heat of 6	1 Heat of 6		
	1 Heat of 4	1 heat of 6	1 Heat of 6		
	1 Heat of 4				
	1 Heat of 4				
	1 Heat of 5				
	1 Heat of 5				
	1 Heat of 5				
	1 Heat of 5				
	Top 2 to 1/4 Final	Winner to 1/4 Final	Top 2 to Semi Final	Top 3 to Final	
45 Riders	1 Heat of 4	1 Heat of 3	1 Heat of 5	1 Heat of 4	1 Heat of 6
	1 Heat of 4	1 Heat of 3	1 Heat of 5	1 Heat of 4	



	1 Heat of 4	1 Heat of 3	1 Heat of 5	1 Heat of 4	
	1 Heat of 4	1 Heat of 3	1 Heat of 5		
	1 Heat of 4	1 Heat of 3	1 Heat of 4		
	1 Heat of 5	1 Heat of 3	1 Heat of 4		
	1 Heat of 5	1 Heat of 3			
	1 Heat of 5	1 Heat of 4			
	1 Heat of 5				
	1 Heat of 5				
	Top 2 to 1/4 Final	Winner to 1/4 Final	Top 2 to Semi Final	Top 2 to Final	
46 Riders	1 Heat of 4	1 Heat of 3	1 Heat of 5	1 Heat of 4	1 Heat of 6
	1 Heat of 4	1 Heat of 3	1 Heat of 5	1 Heat of 4	
	1 Heat of 4	1 Heat of 3	1 Heat of 5	1 Heat of 4	
	1 Heat of 4	1 Heat of 3	1 Heat of 5		
	1 Heat of 5	1 Heat of 3	1 Heat of 4		
	1 Heat of 5	1 Heat of 3	1 Heat of 4		
	1 Heat of 5	1 Heat of 4			
	1 Heat of 5	1 Heat of 4			
	1 Heat of 5				
	1 Heat of 5				
	Top 2 to 1/4 Final	Winner to 1/4 Final	Top 2 to Semi Final	Top 2 to Final	
47 Riders	1 Heat of 4	1 Heat of 3	1 Heat of 5	1 Heat of 4	1 Heat of 6
	1 Heat of 4	1 Heat of 3	1 Heat of 5	1 Heat of 4	
	1 Heat of 4	1 Heat of 3	1 Heat of 5	1 Heat of 4	
	1 Heat of 5	1 Heat of 3	1 Heat of 5		
	1 Heat of 5	1 Heat of 3	1 Heat of 4		
	1 Heat of 5	1 Heat of 4	1 Heat of 4		
	1 Heat of 5	1 Heat of 4			
	1 Heat of 5	1 Heat of 4			
	1 Heat of 5				
	1 Heat of 5				
	Top 2 to 1/4 Final	Winner to 1/4 Final	Top 2 to Semi Final	Top 2 to Final	
48 Riders	1 Heat of 4	1 Heat of 3	1 Heat of 5	1 Heat of 4	1 Heat of 6
	1 Heat of 4	1 Heat of 3	1 Heat of 5	1 Heat of 4	
	1 Heat of 5	1 Heat of 3	1 Heat of 5	1 Heat of 4	
	1 Heat of 5	1 Heat of 3	1 Heat of 5		
	1 Heat of 5	1 Heat of 4	1 Heat of 4		

1 Heat of 5                      1 Heat of 4                      1 Heat of 4  
 1 Heat of 5                      1 Heat of 4  
 1 Heat of 5                      1 Heat of 4  
 1 Heat of 5  
 1 Heat of 5

Top 2 to 1/4 Final                      Winner to 1/4 Final                      Top 2 to Semi Final                      Top 2 to Final

**Qualifying                      LCQ                      1/4 Final                      Semi FINAL                      FINAL**

49 Riders	1 Heat of 4	1 Heat of 3	1 Heat of 5	1 Heat of 4	1 Heat of 6
	1 Heat of 5	1 Heat of 3	1 Heat of 5	1 Heat of 4	
	1 Heat of 5	1 Heat of 3	1 Heat of 5	1 Heat of 4	
	1 Heat of 5	1 Heat of 4	1 Heat of 5		
	1 Heat of 5	1 Heat of 4	1 Heat of 4		
	1 Heat of 5	1 Heat of 4	1 Heat of 4		
	1 Heat of 5	1 Heat of 4			
	1 Heat of 5	1 Heat of 4			
	1 Heat of 5				
	1 Heat of 5				
Top 2 to 1/4 Final					
	Winner to 1/4 Final		Top 2 to Semi Final	Top 2 to Final	

50 Riders	1 Heat of 5	1 Heat of 3	1 Heat of 5	1 Heat of 4	1 Heat of 6
	1 Heat of 5	1 Heat of 3	1 Heat of 5	1 Heat of 4	
	1 Heat of 5	1 Heat of 4	1 Heat of 5	1 Heat of 4	
	1 Heat of 5	1 Heat of 4	1 Heat of 5		
	1 Heat of 5	1 Heat of 4	1 Heat of 4		
	1 Heat of 5	1 Heat of 4	1 Heat of 4		
	1 Heat of 5	1 Heat of 4			
	1 Heat of 5	1 Heat of 4			
	1 Heat of 5				
	1 Heat of 5				
Top 2 to 1/4 Final					
	Winner to 1/4 Final		Top 2 to Semi Final	Top 2 to Final	

51 Riders	1 Heat of 6	1 Heat of 3	1 Heat of 5	1 Heat of 4	1 Heat of 6
	1 Heat of 5	1 Heat of 4	1 Heat of 5	1 Heat of 4	
	1 Heat of 5	1 Heat of 4	1 Heat of 5	1 Heat of 4	
	1 Heat of 5	1 Heat of 4	1 Heat of 5		
	1 Heat of 5	1 Heat of 4	1 Heat of 4		
	1 Heat of 5	1 Heat of 4	1 Heat of 4		
	1 Heat of 5	1 Heat of 4			
	1 Heat of 5	1 Heat of 4			



	1 Heat of 5	1 Heat of 4			
	1 Heat of 5				
	1 Heat of 5				
	Top 2 to 1/4 Final				
		Winner to 1/4 Final	Top 2 to Semi Final	Top 2 to Final	

52 Riders	1 Heat of 6	1 Heat of 4	1 Heat of 5	1 Heat of 4	1 Heat of 6
	1 Heat of 6	1 Heat of 4	1 Heat of 5	1 Heat of 4	
	1 Heat of 5	1 Heat of 4	1 Heat of 5	1 Heat of 4	
	1 Heat of 5	1 Heat of 4	1 Heat of 5		
	1 Heat of 5	1 Heat of 4	1 Heat of 4		
	1 Heat of 5	1 Heat of 4	1 Heat of 4		
	1 Heat of 5	1 Heat of 4			
	1 Heat of 5	1 Heat of 4			
	1 Heat of 5				
	1 Heat of 5				
	Top 2 to 1/4 Final	Winner Only to 1/4 final	Top 2 to Semi Final	Top 2 to Final	

53 Riders	1 Heat of 6	1 Heat of 5	1 Heat of 5	1 Heat of 4	1 Heat of 6
	1 Heat of 6	1 Heat of 4	1 Heat of 5	1 Heat of 4	
	1 Heat of 6	1 Heat of 4	1 Heat of 5	1 Heat of 4	
	1 Heat of 5	1 Heat of 4	1 Heat of 5		
	1 Heat of 5	1 Heat of 4	1 Heat of 4		
	1 Heat of 5	1 Heat of 4	1 Heat of 4		
	1 Heat of 5	1 Heat of 4			
	1 Heat of 5	1 Heat of 4			
	1 Heat of 5				
	1 Heat of 5				
	Top 2 to 1/4 Final	Winner to 1/4 Final	Top 2 to Semi Final	Top 2 to Final	

	<b>Qualifying</b>	<b>LCQ</b>	<b>1/4 Final</b>	<b>Semi FINAL</b>	<b>FINAL</b>
54 Riders	1 Heat of 6	1 Heat of 5	1 Heat of 5	1 Heat of 4	1 Heat of 6
	1 Heat of 6	1 Heat of 5	1 Heat of 5	1 Heat of 4	
	1 Heat of 6	1 Heat of 4	1 Heat of 5	1 Heat of 4	
	1 Heat of 6	1 Heat of 4	1 Heat of 5		
	1 Heat of 5	1 Heat of 4	1 Heat of 4		
	1 Heat of 5	1 Heat of 4	1 Heat of 4		
	1 Heat of 5	1 Heat of 4			
	1 Heat of 5	1 Heat of 4			

1 Heat of 5

1 Heat of 5

Top 2 to 1/4 Final

Winner Only to 1/4 final

Top 2 to Semi Final

Top 2 to Final

55 Riders	1 Heat of 6	1 Heat of 5	1 Heat of 5	1 Heat of 4	1 Heat of 6
	1 Heat of 6	1 Heat of 5	1 Heat of 5	1 Heat of 4	
	1 Heat of 6	1 Heat of 5	1 Heat of 5	1 Heat of 4	
	1 Heat of 6	1 Heat of 4	1 Heat of 5		
	1 Heat of 6	1 Heat of 4	1 Heat of 4		
	1 Heat of 5	1 Heat of 4	1 Heat of 4		
	1 Heat of 5	1 Heat of 4			
	1 Heat of 5	1 Heat of 4			
	1 Heat of 5				
	1 Heat of 5				
	Top 2 to 1/4 Final	Winner to 1/4 Final	Top 2 to Semi Final	Top 2 to Final	

56 Riders	1 Heat of 6	1 Heat of 5	1 Heat of 5	1 Heat of 4	1 Heat of 6
	1 Heat of 6	1 Heat of 5	1 Heat of 5	1 Heat of 4	
	1 Heat of 6	1 Heat of 5	1 Heat of 5	1 Heat of 4	
	1 Heat of 6	1 Heat of 5	1 Heat of 5		
	1 Heat of 6	1 Heat of 4	1 Heat of 4		
	1 Heat of 6	1 Heat of 4	1 Heat of 4		
	1 Heat of 5	1 Heat of 4			
	1 Heat of 5	1 Heat of 4			
	1 Heat of 5				
	1 Heat of 5				
	Top 2 to 1/4 Final	Winner Only to 1/4 final	Top 2 to Semi Final	Top 2 to Final	

57 Riders	1 Heat of 6	1 Heat of 5	1 Heat of 5	1 Heat of 4	1 Heat of 6
	1 Heat of 6	1 Heat of 5	1 Heat of 5	1 Heat of 4	
	1 Heat of 6	1 Heat of 5	1 Heat of 5	1 Heat of 4	
	1 Heat of 6	1 Heat of 5	1 Heat of 5		
	1 Heat of 6	1 Heat of 5	1 Heat of 4		
	1 Heat of 6	1 Heat of 4	1 Heat of 4		
	1 Heat of 6	1 Heat of 4			
	1 Heat of 5	1 Heat of 4			
	1 Heat of 5				
	1 Heat of 5				
	Top 2 to 1/4 Final	Winner to 1/4 Final	Top 2 to Semi Final	Top 2 to Final	

58 Riders	1 Heat of 6	1 Heat of 5	1 Heat of 5	1 Heat of 4	1 Heat of 6
-----------	-------------	-------------	-------------	-------------	-------------



1 Heat of 6	1 Heat of 5	1 Heat of 5	1 Heat of 4
1 Heat of 6	1 Heat of 5	1 Heat of 5	1 Heat of 4
1 Heat of 6	1 Heat of 5	1 Heat of 5	
1 Heat of 6	1 Heat of 5	1 Heat of 4	
1 Heat of 6	1 Heat of 5	1 Heat of 4	
1 Heat of 6	1 Heat of 4		
1 Heat of 6	1 Heat of 4		
1 Heat of 5			
1 Heat of 5			

Top 2 to 1/4 Final	Winner Only to 1/4 final	Top 2 to Semi Final	Top 2 to Final	
<b>Qualifying</b>	<b>LCQ</b>	<b>1/4 Final</b>	<b>Semi FINAL</b>	<b>FINAL</b>

59 Riders	1 Heat of 6	1 Heat of 5	1 Heat of 5	1 Heat of 4	1 Heat of 6
	1 Heat of 6	1 Heat of 5	1 Heat of 5	1 Heat of 4	
	1 Heat of 6	1 Heat of 5	1 Heat of 5	1 Heat of 4	
	1 Heat of 6	1 Heat of 5	1 Heat of 5		
	1 Heat of 6	1 Heat of 5	1 Heat of 4		
	1 Heat of 6	1 Heat of 5	1 Heat of 4		
	1 Heat of 6	1 Heat of 5			
	1 Heat of 6	1 Heat of 4			
	1 Heat of 6				
	1 Heat of 5				
	Top 2 to 1/4 Final	Winner to 1/4 Final	Top 2 to Semi Final	Top 2 to Final	

60 Riders	1 Heat of 6	1 Heat of 5	1 Heat of 5	1 Heat of 4	1 Heat of 6
	1 Heat of 6	1 Heat of 5	1 Heat of 5	1 Heat of 4	
	1 Heat of 6	1 Heat of 5	1 Heat of 5	1 Heat of 4	
	1 Heat of 6	1 Heat of 5	1 Heat of 5		
	1 Heat of 6	1 Heat of 5	1 Heat of 4		
	1 Heat of 6	1 Heat of 5	1 Heat of 4		
	1 Heat of 6	1 Heat of 5			
	1 Heat of 6	1 Heat of 5			
	1 Heat of 6				
	1 Heat of 6				

Top 2 to 1/4 Final	Winner Only to 1/4 final	Top 2 to Semi Final	Top 2 to Final
--------------------	--------------------------	---------------------	----------------